

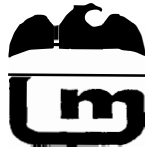

# Instruction Manual

MODEL #5503  
*Cheese Warmer/Dispenser*





**GOLD MEDAL<sup>®</sup> PRODUCTS CO.**

# SAFETY PRECAUTIONS

|   |  |
|---|--|
|  | <b>⚠ CAUTION</b>   |
|   | This equipment is designed and sold for commercial use only. This equipment is not to be used by the consumer in home use. Do not allow direct contact of this equipment by the public when used in food service locations. Only personnel trained and experienced in the equipment operation may operate this equipment. Carefully read all installation instructions before operating the equipment. |

|   |   |
|---|---|
|  | <b>⚠ WARNING</b>  |
|   | Always wear safety glasses when servicing this equipment. |

|   |  |
|---|--|
|  | <b>⚠ WARNING</b>   |
|   | NEVER put your fingers or any object into the heating area. We do NOT assume any liability for injury due to careless handling or operation of this equipment. |

|   |  |
|---|--|
|  | <b>⚠ WARNING</b>   |
|   | Any alterations to this equipment will void the warranty and may cause a dangerous situation. NEVER make alterations to the equipment. |

|   |  |
|---|--|
|  | <b>⚠ DANGER</b>  |
|   | Machine must be properly grounded to prevent electrical shock to personnel. Do NOT immerse the equipment in water. Always unplug the equipment before cleaning or servicing. |

## NOTE

The information, specifications and illustrations contained in this manual represent the latest data available at time of publication. Right is reserved to make changes as required at the discretion of Gold Medal Products Company without notice.

## TABLE OF CONTENTS

|                     |   |
|---------------------|---|
| General Information | 2 |
| Dispenser Benefits  | 3 |
| Dispenser Features  | 4 |
| Installation        | 5 |
| Product Placement   | 5 |
| Using the Dispenser | 6 |
| Cleaning            | 6 |
| Problem Solving     | 7 |

## General Information

The instructions in this booklet serve as a guide to dispenser installation, usage and cleaning, along with some problem solving solutions. Should dispenser require repair, please consult with Gold Medal Service Department at 1-800-543-0862.

## Specifications

**Size:** Height: 26" x Width: 10" x Depth 16"  
**Weight:** 18 lbs. Voltage: 120 AC 60 Hz, Watts 200, Amps 2

## Dispenser Features

- 1) Temperature Indicator
- 2) Start Button
- 3) Clamp
- 4) Cam
- 5) Rotor
- 6) Tube Slot
- 7) Tube
- 8) Tray
- 9) Warming Tray
- 10) Oven

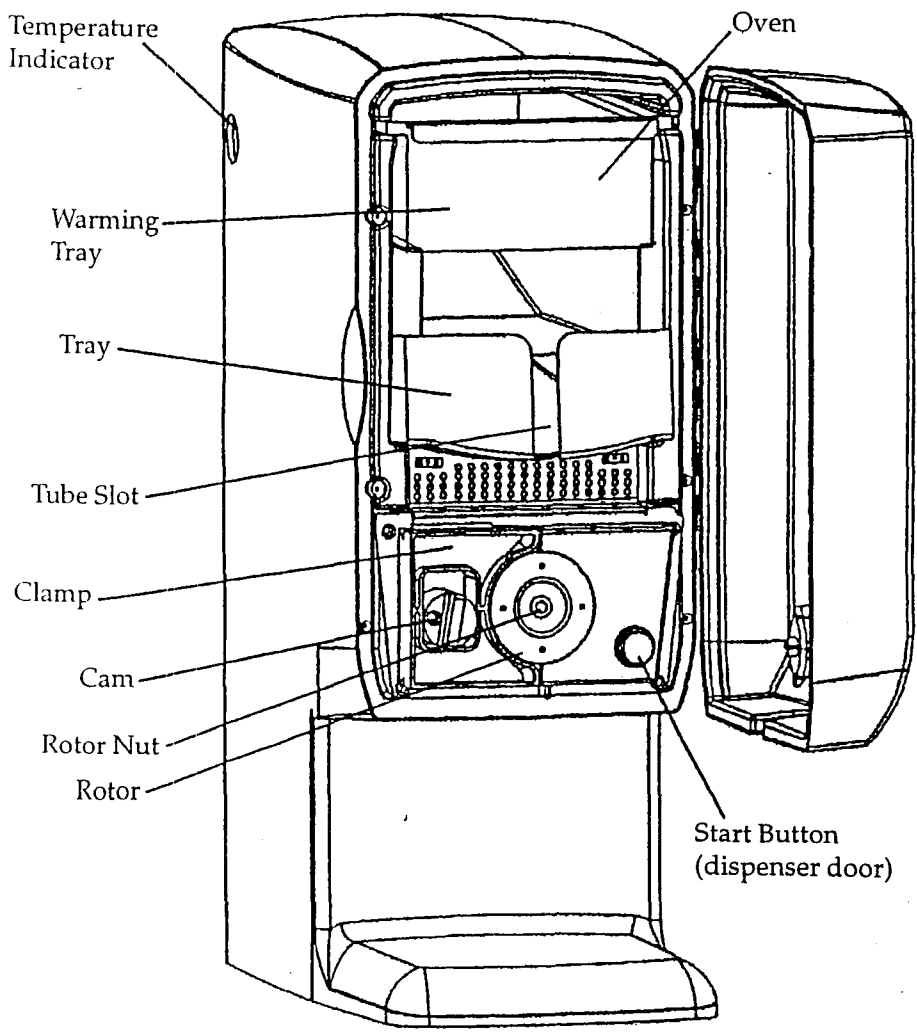

## Installation

- 1) Plug electrical cord into 120 volt outlet.
- 2) Preheat the dispenser for approximately 1 hour.

## Product Placement

- 1) Preheat bag of product to between 140° to 150°F.
- 2) Open door by pulling from left to right and place product on tray with spout and tube directed downward.

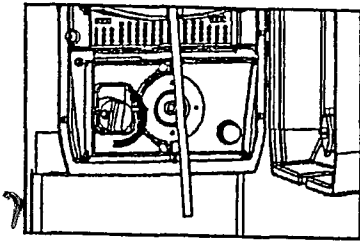

- 3) Open tube clamp by rotating cam counter clockwise.

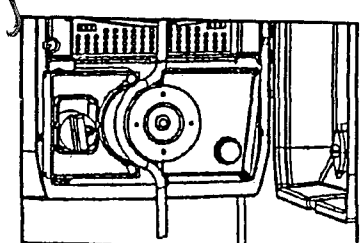

- 4) Guide tube through pump slot from top to bottom.

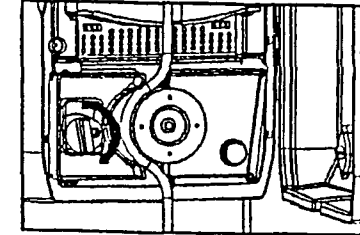

- 5) Close clamp by rotating cam clockwise.

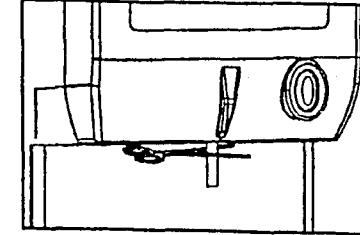

- 6) Cut off end of tube below door with clean, sanitized scissors. Tip of tube should be visible and extend outside of dispenser to maintain sanitary conditions and to aid in dispensing product.

## How to Dispense Product

- 1) Hold food under dispensing tube to receive product.
- 2) Press dispensing button until desired amount of product has been dispensed and release button or press once for portion controlled units.

## Cleaning

- 1) Open door by pulling forward from the left side.

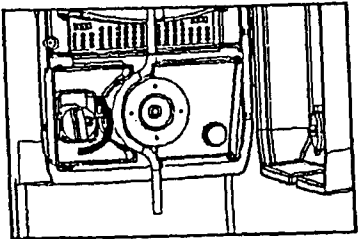

- 2) Open tube clamp by rotating cam counter clockwise.

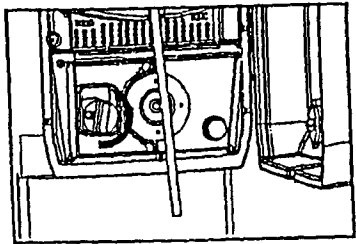

- 3) Remove tube from pump slot by grabbing tube from lower end and pulling upward to tray.

- 4) Take out tubing and product bag by continuing to pull tubing upward.

- 5) Remove empty product bag with tubing from oven.

- 6) Wipe down outside of the dispenser with a clean damp cloth if necessary.

For high volume locations consider the Gold Medal Bag Prewarmer #2264. Ask Customer Service for more details.  
1-800-543-0862.

## Problem Solving

| Problem                                       | Cause  | Solution  |
|---|--|---|
| Nothing is working                            | Electrical failure   | Push plug securely into outlet<br>Try another outlet<br>Check outlets circuit breaker |
| Door will not close                           | Clamp open<br>Basket not fully in oven   | Close hose clamp<br>Push basket in further  |
| No product dispensing<br>(have suction sound) | Out of product<br>Evacuated product faster than could feed to spout              | Replace empty bag<br>Wait a couple of minutes for product to flow to spout            |
| No product dispensing<br>(no suction sound)   | Tube not in slot<br>Clamp not closed   | Check tube<br>Close clamp   |
| Product is leaking                            | Clamp not closed<br>Tube loose from spout  | Close hose clamp<br>Tighten tube on spout   |
| Tube not reaching bottom of clamp             | Spout not seated in receptacle   | Seat spout in receptacle  |
| Product cold                                  | Dispenser door left open<br>No electricity to dispenser<br>Product not preheated | Close door<br>Check power source<br>Preheat product                                   |
| Excess product in bag                         | Spout not seated in receptacle<br>Folds in bag                                   | Seat spout<br>Lay bag flat on tray  |

In order to adjust the portion control please use the following steps:

1. Unplug the machine and remove the back panel
  - a. Using a Phillips screwdriver, remove all the screws
  - b. Once screws are removed, take the metal plate off the back of the machine
2. Locate the dipswitches on the circuit board
  - a. Dipswitches are located in a small blue or red box on the circuit board
  - b. Dipswitches should be numbered left to right 1,2, 3, 4,5, & 6.
3. Adjust the dipswitches to dispense the desired portion according to the table below:

|                    |  |
|--------------------|--|
| 2 oz. Serving      | #'s 1,2,3 and 5 on                     |
| 3 oz. Serving      | #'s 1,3 and 6 on                       |
| 4 oz. Serving      | #'s 1,5 and 6 on                       |
| 5 oz. Serving      | #'s 1,4,5 and 6 on                     |
| No portion Control | All dip switches set to "off" position |

The actual amount of portion is variable depending on numerous factors such as cheese temp., viscosity, dispensing tube flexibility & size, etc. The dipswitches are numbered from shortest to longest run time with #1 being the shortest (least amount dispensed) and #6 being the longest (greatest amount dispensed). Portion size can be controlled by customizing the combination of dipswitches that are "on" at any one time.